

## Guidelines for Using Urine and Blackwater Diversion Systems in Single-Family Homes



**Author: Maria Lennartsson & Peter Ridderstolpe**

Editor: Gunnar Norén, Executive Secretary, Coalition Clean Baltic  
Language: Carl Etnier and Diana Chace

*This brochure discusses two different systems for ecological sanitation in single family homes: urine diversion and blackwater diversion. It presents practical information and technical guidelines for installing and operating the systems, as well as for using urine and blackwater in agriculture.*

## Introduction

The primary purpose of a wastewater system is to provide a good sanitary environment in and around the home. This can be done in many different ways. A common solution for single-family homes outside urban areas has been to infiltrate the wastewater into the ground, after treatment in a septic tank. This is safe as long as the wastewater is discharged below the surface, and soil conditions and groundwater levels are appropriate.

In the last decade, it has become more common to view wastewater as a resource. In the first place, water itself is regarded as a limited resource. Also, there is increased recognition that the nutrients in wastewater can be recycled through agriculture if the material can be properly disinfected. This has led to the development of new wastewater technologies, including source-separating systems in which either urine or blackwater (urine + feces) is collected separately. In this way, between 70 and 90% of all the nutrients in wastewater can be collected and used in agriculture. We will use the term *ecological sanitation* to describe this method of closing nutrient loops.

For these new technologies to be successful, changes are required in the planning, use, and oversight of wastewater treatment systems. Designing these systems involves different decision-making processes than designing conventional systems. More actors have to be consulted and included in decision-making at an early stage in order to design a complete system that takes each stakeholder's specific concerns into account.

Inside the home, there is a different type of toilet to use, which requires some learning and new routines to ensure the system's proper use. At the other end of the pipe, for the farmer to be interested in using the products in agriculture, there needs to be an organization and/or treatment method that ensures that the product is of high quality, safe to use, and not too aesthetically offensive. Whether the standards are developed and enforced by the individual owner of the sanitation system or by local government, the standards and recommendations are similar.

This brochure will give some practical recommendations and guidelines on how to plan and design a source-separating wastewater system, including recommendations on how to plan for the use of end products in agriculture.

Different countries and different regions have different policies and guidelines for this type of activity. Therefore, this brochure will not cover legal and administrative aspects or monitoring of ecological sanitation systems.

It is useful to think of a new sanitation project in three stages:

- Planning the system
- Developing the system
- Use and maintenance of the system

## Planning and designing the system

With knowledge and understanding, decisions at the planning and design stage can help avoid later problems. These decisions include:

- What system to use?
- Who will treat and use the final product?
- In addition to up-front investment costs, what other costs are there for the various alternatives?

Below are some issues that need to be discussed as early in the process as possible to avoid problems.

### Homeowner

- What local regulations restrict or govern the design of an onsite wastewater system?
- Do I want to use the final products myself?
- Which is easier to use, urine or blackwater?
- Where and how will I use them?
- If I will not use them, is there anyone interested in taking them? And at what cost? Include a cost for organizing the management of final products.
- Who shall provide storage facilities for disinfection?

### Farmer

- Where and how can the final products be used?
- What volumes have to be produced for use to be economically worthwhile?
- What types of final product is the farmer interested in? Urine? Blackwater?
- What equipment can be used for collection and spreading of the product?
- Can the final product be combined with the farmer's own production of organic fertilizers?
- It is important to draw up an agreement with the farmer early in the design of the management system.

## Developing the system

Once a decision is made on what type of system to build and how to manage the resource, the development of the system begins. This includes more than the construction of the wastewater system at the property. It also includes planning and organizing the infrastructure for recycling the final products.

For an individual system contained on one property, the owner, producer, entrepreneur, and farmer are the same person, and he or she can plan the disinfection process and final use according to agricultural and other needs. The organizational challenges are minimal in a situation like this, but relatively few homeowners wish to manage all aspects of their wastewater reuse.

A larger system has different actors: the producer (homeowner), the collector (possibly the farmer), and the user (farmer). Here, having a written agreement which clearly defines the responsibilities of each stakeholder will help prevent disagreement and encourage participation. Some of the issues to be covered by the agreement include:

- Where are the boundaries of responsibility and liability of each stakeholder?
- Who is responsible for collections and at what time interval?
- Who pays whom how much, and what do they get in return?
- Who provides facilities for storage and disinfection?
- How is the quality (pathogens, contaminants, nutrient content, etc.) of the product ensured?

## Use and maintenance of the system

Homeowners prefer system that is convenient to use and easily maintained. This will be covered later in this brochure. On a larger scale, in order for the system to be safe and effective, the product/fertilizer has to be of the best possible quality. Below are some issues to consider in maintaining quality:

### Homeowner

- What motivates the homeowner may vary from one household to the other.
- A sanitary and environmentally safe system that is not too expensive is probably what most homeowners want.
- Information on the overall benefits of the system will increase motivation.
- Motivated users produce high quality fertilizer.

### Farmer

- The motivation for the farmer is that he/she gets an organic fertilizer that is rich in nutrients and safe to use. If it is relatively cheap, that is an extra benefit.
- Continuous control of quality and nutrient content.
- Feedback to producers on quality and contamination.

# Urine diversion systems

A urine diversion system usually collects and makes use of the urine only. (Treatment options for the rest of the wastewater flow are discussed on pp. 14-15.) Urine contains about 70% of the nutrients released from the human body, including 85% of the nitrogen and 65% of the phosphorus and potassium. Urine can be managed relatively easily both on an individual and regional level. A very simplified system is described below:

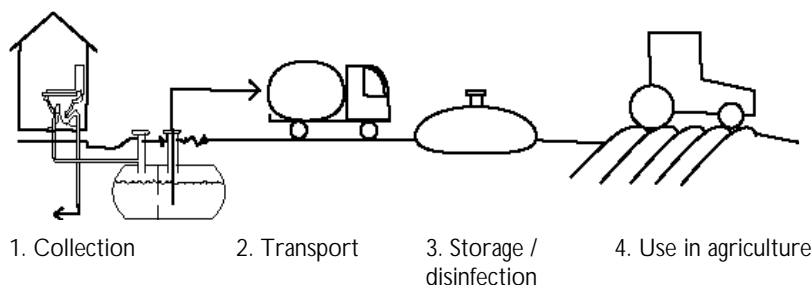

Technical requirements for each component will be further described later in this brochure.

## Collection

Collection has two purposes: i) to collect urine that is produced; and ii) to store the urine until it can be transported. The number of users at each facility will strongly influence the economics, but a reasonable solution in most cases will be storage capacity for a few months' urine output at the collection site.

### Individual system

- the collection and facilities for storage are related to how the urine will be used.
- the seasonal use of urine and the number of users determines the volume of the storage tank.

### Multi-user system

- the size of the collection at the property is related to the distance to the farm and the cost of transportation.
- the collection can be managed by an entrepreneur or a farmer.

## Transportation

Urine should be transported in closed containers, primarily to avoid human exposure and odor problems, but also to limit the loss of nitrogen in the form of ammonia to the air. The tank which the urine is transported in should be clean, to prevent unnecessary contamination. Having specified cleaning procedures if the tanks are otherwise used to haul septage may be very important for reducing contamination.

### Individual system

- there is no need for transportation

### Multi-user system

- collection carried out on a regular basis.
- any container may be used as long as it can withstand the harsh environment. urine has a high pH (~10).

## Storage / Disinfection

Storing urine for at least six months is the cheapest and simplest way to disinfect the product. However, if the urine is used in household production, there are no restrictions on storage time.<sup>1</sup>

### Individual system

- in a household production system, the homeowner can use urine as needed in agriculture with no specific requirements for storage time.

### Multi-user system

- at least 6 months of storage before use in agriculture. Facilities needed at a suitable location.

## Use in agriculture

The optimal use of the urine is on productive, arable land. Use in production of food crops, especially cereals, has been very successful in Sweden.

### Individual system

- the owner can use urine as needed in agricultural production.
- primarily the fertilizer should be used for agricultural production.
- avoid using urine vegetables that will be consumed raw

### Multi-user system

- if properly managed and stored, the nutrient content corresponds to commercial fertilizers but with lower content of heavy metals.
- urine is a suitable fertilizer for cereals.

<sup>1</sup> Recommendations made by the Swedish Institute for Infectious Disease Control (see Höglund, C. in reference list). Check national variations in legal requirements with local authorities..

# Urine diverting systems, technical solutions and requirements

## Toilet and collection system

Research has shown which materials and design features work well. Issues to be considered are summarized below.

Design	
<b>The system</b>	<ul style="list-style-type: none"><li>• Use no metals in the system, to avoid metal contamination of the urine (urine is very corrosive).</li><li>• Do not ventilate the tank, to avoid loss of nutrients (ammonia nitrogen).</li></ul>
<b>Piping / sewer</b>	<ul style="list-style-type: none"><li>• Minimum diameter 50 mm.</li><li>• Minimum 1% slope and ensure no depressions in the pipe.</li></ul>
<b>Collection tank</b>	<ul style="list-style-type: none"><li>• The volume is calculated based on type of toilet, frequency of emptying, the number of users, and what part of the day they use the system.</li><li>• The outlet of the filling pipe should be placed in the bottom of the tank.</li><li>• The tank needs an access port placed above the filling pipe.</li><li>• If the collection tank is used both for collection and for storage/disinfection, an alternative with two tanks has to be considered.</li><li>• Materials suitable for the tank are plastic and concrete (do NOT use metals).</li><li>• The tank is equipped with an outlet to prevent overflow. This outlet should ideally be connected to the graywater treatment.</li></ul>

## Storing and disinfection

As mentioned before, urine is recommended to be stored for 6 months for disinfection, unless it is used on private property for private use<sup>2</sup>. This section focuses on storage for multi-user systems

Design	
<b>The system</b>	<ul style="list-style-type: none"><li>• No metals in the system to avoid metal contamination of the urine. No ventilation or open surfaces to avoid loss of nutrients (nitrogen/ammonia).</li></ul>
<b>Piping / sewer</b>	<ul style="list-style-type: none"><li>• Allow large diameters, &gt;120 mm, for all pipe connections.</li></ul>
<b>Storage tank</b>	<ul style="list-style-type: none"><li>• The volume has to be calculated based on the number of users, filling procedures, frequency of use in agriculture and a storage time of at least 6 months</li><li>• The urine can be stored in simple concrete structures provided with a seal to avoid ammonia loss. (for example, a floating seal)</li><li>• Other storage systems (such as PVC-balloons) that are used for agricultural purposes (liquid manure) may also serve for urine storage.</li><li>• The tank should be equipped with an outlet to prevent overflow.</li></ul>

## Use in agriculture

The potential for use of urine in agriculture depends on the farmer's crops and available equipment. As far as possible, the ordinary agricultural equipment for spreading manure should be used. The following information is based on crop trials:

Lessons learned	
<b>Crops</b>	<ul style="list-style-type: none"><li>• Cereals, vegetables (avoid vegetables that will be consumed raw), fruit and berries.</li></ul>
<b>Nutrients</b>	<ul style="list-style-type: none"><li>• Urine is a well balanced (NPK) source of nutrients and contains easily accessible plant nutrients. The exact nutrient content depends on the food consumption. Swedish researchers report that the NPK ratio in urine is 12 - 1.1 – 3.3.</li><li>• The nitrogen is easily lost if the urine is not stored and spread appropriately.</li><li>• No plant toxicity has been detected.</li><li>• The most effective time to spread the urine for plant uptake is on the growing crop, since a high percentage of the nutrients are water soluble at time of application.</li></ul>
<b>Spreading urine</b>	<p>The highest risk of ammonia loss occurs during spreading. The following recommendations aim to minimize the loss.:</p> <ul style="list-style-type: none"><li>• Spreading should take place on a cloudy and humid day.</li><li>• Spreading should be carried out as close to the ground as possible. (Avoid spraying into the air.)</li><li>• Plow down the urine as quickly as possible after spreading.</li></ul>

---

<sup>2</sup> Recommendations made by the Swedish Institute for Infectious Disease Control (see Höglund, C. in reference list). Check national variations in legal requirements with local authorities.

## Urine diverting, dehydrating toilet

The picture below shows a household with a urine-diverting, single flush toilet installed. The toilet uses a small amount of water (0.1 l/flush) to rinse the urine bowl. The urine/water mix is collected in a tank and the feces are collected dry in a bin underneath the toilet. The bin is placed in an enclosed ventilated space where the content is partially dehydrated. (The system may be used in houses with no basement, using a collection device inside the house (the Throne). See illustration below.) After disinfection, urine and feces can be used on cropland. The models with a toilet bowl made of porcelain are easiest to clean, and they look like an ordinary toilet on the outside.

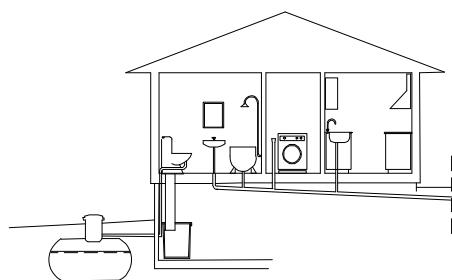

Urine tank      Fecal bin      Graywater to treatment

### Equipment and Dimensions

For a household (of 5 persons) the system requires the following equipment:

	Household	Per person
Urine tank	2 m <sup>3</sup> (6 months collection) 4 m <sup>3</sup> (1 year collection)	~0.75 m <sup>3</sup> (1 year collection) <sup>3</sup>
Collection bin for feces	2 bins (6 months collection) <sup>4</sup>	
Graywater treatment	See pages 14-15	

### Installation

Proper installation helps provide a healthy, sanitary environment for the users. The toilet system should not leak or produce odors, and should enable simple and safe management of the final products. Below are some issues to keep in mind:

- **Be sure to follow the installation instructions from the manufacturer.**
- Leakage of urine creates an odor problem. Leakage in the connections in the urine pipe has been a recurring problem, according to Swedish research. **Leakage can be avoided by making connections correctly.**
- Blockages in the trap of the urine pipe is a recurring problem. Normally, with regular cleaning, this is easy to take care of at an early stage. As a preventive measure, however, if a trap is used, **the connections should be removable, in case a change of trap is needed.**
- The collection bin under the toilet may produce odors if the enclosing is not kept under constant negative pressure. The manufacturer's advice is to **install adequate ventilation from the feces collection bin.**
- If a collection bin is used, **make sure there is enough workspace and height to exchange the bins.**
- Prepare storage space for the collection bins, preferably in an outdoor, rain proof and rodent-safe place.

The toilet need not be built in to the house. For a house with no space under the floor a special "throne" model has been developed. The illustration below shows two types of installation, one with space under the floor and the other without.

Installation with storage space under the floor

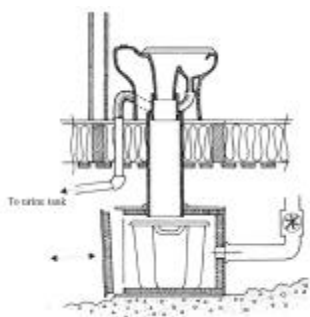

Installation with no storage space under the floor

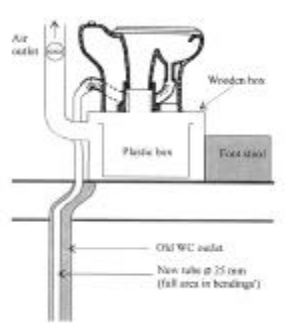

<sup>3</sup> The volume is based on ~0.5 m<sup>3</sup> urine and ~0.25 m<sup>3</sup> flush water

<sup>4</sup> 2 bins is enough for 6 months collection according to the manufacturer (Wost Man Ecology AB)

## Urine diverting, double-flush toilet

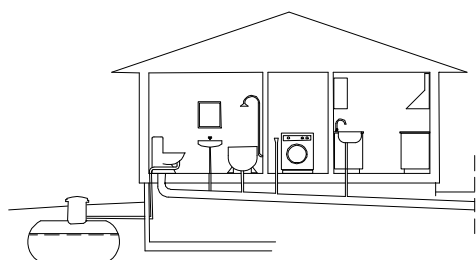

Urine tank

Graywater to treatment

The toilet has a small bowl where urine is collected and a large bowl for the feces.

The illustration below shows a house with a urine diverting, double-flush toilet installed.

The toilet has two flushing systems, one for the urine bowl and one for the fecal bowl. Depending on the toilet, 0.1-0.5 liters of water is used to rinse the urine bowl and 2-4 liters to flush the fecal bowl. Urine and water are collected in a tank, and the feces are flushed and treated with the rest of the wastewater (graywater) from the household. After disinfection, urine can be used on arable land. The toilet is made of sanitary porcelain and looks like an ordinary toilet on the outside. The picture below shows the inside of the toilet.

### Toilet models

On the Swedish market there are three toilets available. They are all pictured below.



DS (Wost Man Ecology),



Dubletten (BB Innovation)



Nordic 393U (Gustavsberg)

### Equipment

For a household (of 5 persons) the system requires the following:

Household	
Urine tank	2-3 m <sup>3</sup> (6 months) 4-6 m <sup>3</sup> (1 year) <sup>5</sup>
Greywater treatment	See pages 14-15

### Installation

Proper installation helps provide a healthy, sanitary environment for the users. The toilet system should not leak or produce odors, and should enable simple and safe management of the final products. Below are some of the issues to keep in mind:

- Be sure to follow the installation instructions from the manufacturer.
- Leakage of urine creates an odor problem. Leakage in the connections in the urine pipe has been one recurring problem, according to Swedish research. **Leakage can be avoided by making connections correctly.**
- Blockages in the trap of the urine pipe is a recurring problem. Normally, with regular cleaning, this is easy to take care of at an early stage. As a preventive measure, however, if a trap is used, **the connections should be removable, in case a change of trap is needed.**

The toilet does not have to be built into the structure. It is important to allow for a urine pipe with a dimension of <75 mm to carry the urine to the collection tank.

The illustrations below show installation guidelines from one of the manufacturers of urine-diverting toilets.

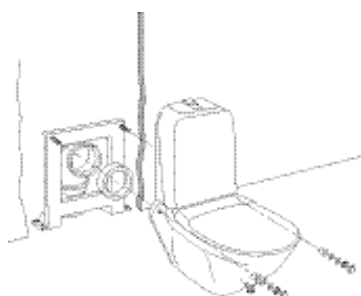

Principles for mounting the double-flush toilet

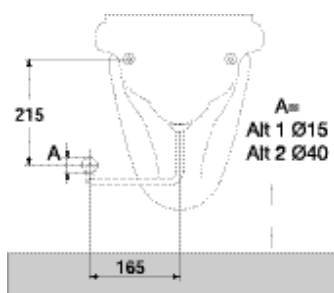

Nordic 393U (Gustavsberg)

<sup>5</sup> The volume of flush water varies from toilet to toilet, 0.1-0.3 l/flush

## Use and maintenance

The system needs regular attention and maintenance. There are some issues connected to the user and his/her behavior and others that are more mechanical.

### User issues

Well-informed users are most motivated to make the system work. The amount of urine collected is closely related to how the toilet is used. In particular, men have to either be seated or make an effort to urinate in the correct bowl. For single-flush toilets, proper use is also very important in preventing odors. The less urine mixed with the feces, the fewer problems with odor will occur.

The urine can be contaminated with small amounts of fecal matter and heavy metals, which come from the body. Fecal matter (pathogen) contamination appears in small amounts in urine and relates to proper use of the toilet system (misdirected fecal matter). This problem is addressed through disinfection of the urine. The content of heavy metals relates to the food consumption; what we take in passes through the body and ends up in the toilet waste. However, the amount of heavy metals in urine is less than in commercial fertilizers.

After producing a clean product, it is important not to contaminate it by adding chemicals or products that should not end up in agriculture.

As for the fecal matter, it is also comparatively clean. It only contains what we have eaten and what has passed through our bodies. To avoid adding unwanted items and chemicals into the soil (and, subsequently, into food production), avoid putting them in the toilet.

- All detergents used in the toilet should be ecolabelled and biodegradable.
- Do not pour or throw anything in the toilet that doesn't belong there. The toilet should not be used for disposal of any other waste than toilet waste.

### Blockages

A trap may not be necessary. However, where it is used, blockages will occur on a regular basis (every 6-24 months, depending on the users). Depositions and hair create the blockages. Roughly 20-25% of the blockages are hard coatings, but most of them are soft and can easily be removed by using a plumber's snake. The hard blockages can be removed with a solution of liquid caustic soda<sup>6</sup>; add it to the pipe, let it stay overnight and flush the trap with water.

- As soon as any sign of reduced flow appears, clean the trap with a plumber's snake.

### Managing fecal material

Depending on the number of users, the collection bin is changed every 2-3 months. Since the bin has been placed in a ventilated space, the content dries up and does not smell too much. The bin will usually be delivered with a lid, and the operation is therefore quite simple. Place the lid on the bin, move it to the storage space, and store without the lid. With a few extra bins, most of the composting process can be carried out in the bins. The content should be composted for at least 12 months, including a final composting with other organic material, which is recommended before use. The material is then regarded as a disinfected soil conditioner for agriculture. For additional sanitary safety, the material should only be used on crops that will be processed.

### Managing urine

The urine tank is emptied regularly. There are different ways to do this, either by pumping the content or by using a septage pumper truck.

Careful—the stored urine smells bad!

---

<sup>6</sup> Caustic soda is not harmful to the environment and increases the pH of the urine solution

For spreading the urine, various techniques are available. For single family households, an ejector system that operates on water pressure (Separett) can be used to sprinkle the garden. For large-scale spreading, equipment used for spreading liquid manure in agriculture may be used.

#### Remaining wastewater flow

Whether a dehydrating or double-flush toilet is used, a large volume of graywater will be produced in the household. For treatment suggestions, see pages 14 and 15.

With a double-flush toilet, the graywater will be mixed with fecal material. This wastewater contains more organic matter and pathogens than ordinary graywater, and should be treated the same way as ordinary, mixed domestic wastewater.

## **Environmental and health protection**

#### Treatment efficiency

With a dehydrating toilet, 90-95% of all nutrients and some organic material in wastewater are collected and therefore become a resource rather than a pollutant. Most pathogens are also removed.

With a double-flush toilet, 70-80% of the nutrients are collected. Combined with graywater treatment, the system reaches about 95% efficiency in reduction of nutrients and organic matter.

More research is needed on the reduction of hormones and pharmaceutical residues in urine. (This is also true for every other type of wastewater treatment.)

#### Human exposure and risks

Urine contains very small amounts of pathogens, and storing urine for some time is sufficient for disinfection. Risk assessments have established that human urine is safe to use if stored for six months.

More research is needed on hormone and pharmaceutical residues in urine. What is known, however, is that the microbial life in soil is far better equipped to degrade naturally existing hormones and organic compounds than aquatic life. This suggests that there are lower risks associated with using urine in agriculture than with treating wastewater in a conventional treatment plant and releasing it to lakes or streams.

## **Management of septic tanks**

The function and durability of treatment, i.e., soil infiltration systems and constructed soil filters, depends on a well-designed pretreatment. The pretreatment is needed to reduce fats, particles, and suspended solids that may clog the structures. See page 14 for information on design and dimensioning.

Pretreatment in a septic tank is sufficient, if the tank is properly maintained. The septic tank needs to be emptied at least once a year to function properly. See that the floating sludge is not removed and that the sludge is only removed from the bottom of the tank. This reduces the odor and allows new wastewater to be 'seeded' with the digesting bacteria originating from the floating sludge.

## Management of blackwater

Blackwater can also be managed either on an individual or a multi-user level. Since blackwater contains many pathogens, managing it is more complicated than managing urine only.

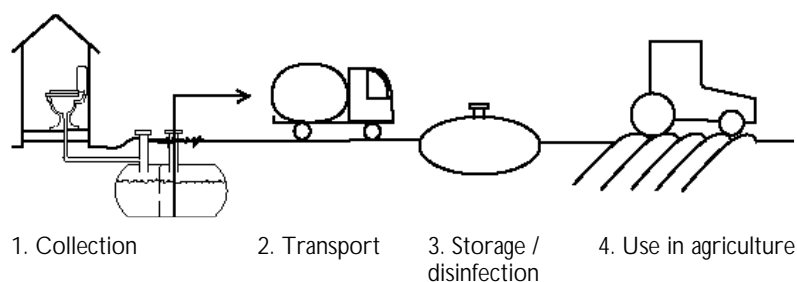

### Collection

Collection has two purposes, i) to collect blackwater, and ii) to store the blackwater until it can be transported. It is best if the collection system can hold a few months' production of blackwater. For larger systems, the collection tank may hold as much as the tank on the septage hauling truck that empties it.

#### Individual system

- if disinfection occurs in the same tank as collection, there must be 2 collection tanks that each hold at least 12 months' output.

#### Multi-user system

- the collection tank has to hold at least 6 months of blackwater production. Larger volumes may be necessary, depending on routines for transport and storage / disinfection.

### Transportation

Blackwater should be transported in closed containers, primarily to avoid human exposure and odor problems, but also to limit the loss of nitrogen in the form of ammonia.

#### Individual system

- there is no need for transportation.

#### Multi-user system

- collection is organized and carried out on a regular basis.
- the collection and transportation may be carried out by an entrepreneur or the farmer who uses the blackwater

### Storage / Disinfection

If no other treatment is carried out, storage over a period of at least 12 months is recommended for blackwater. <sup>7</sup>(Research is being carried out which may result in new recommendations.) In this case, there is no difference between an individual or multi-user system. Storing is the cheapest and easiest way to provide for a disinfected product. Blackwater with a high content of organic matter can also be composted or digested, but this requires a multi-user system with at least 200 households connected and more sophisticated equipment, and thus is much more expensive.

#### Individual system

- Needs at least 12 months of storage. Storage facilities have to be designed to allow storage time.

#### Multi-user system

- Needs at least 12 months of storage. Storage facilities have to be arranged at a suitable location.

### Use in agriculture

The optimal use of these fertilizers is on productive, arable land.

#### Individual system

- Primarily the fertilizer should be used for food production.
- Avoid using blackwater on vegetables that will not be processed afterwards.

#### Multi-user system

- If properly managed and stored, the nutrient content corresponds to commercial fertilizers but with less content of heavy metals.
- It is a very good soil conditioner (contains valuable humus substances).

<sup>7</sup> Little research has been carried out on blackwater, but Swedish recommendations are that a period of 12-24 months is provided for before the product is used in agriculture. Check national variations in legal requirements with local authorities.

## Management of blackwater, technical solutions and requirements

### Toilet and collection

Research is still ongoing and the recommendations made below are based on present knowledge about urine and wastewater in general. Issues that need to be considered are summarized below:

	Design
<b>The system</b>	<ul style="list-style-type: none"><li>• No metals in the system to avoid metal contamination of the blackwater (which is very corrosive).</li><li>• The system needs to be ventilated above the roof to avoid odors.</li></ul>
<b>Piping / sewers</b>	<ul style="list-style-type: none"><li>• The manufacturer of the toilet provides standards on dimensions and slopes for sewers. This varies between manufacturer but is crucial to the functioning of the system.</li></ul>
<b>Collection tank</b>	<ul style="list-style-type: none"><li>• There are a number of toilets on the market with different flushing systems and requirements.</li><li>• The volume is calculated based on choice of toilet, frequency of emptying, the number of users, and the hours of the day they are expected to use it.</li><li>• The outlet of the filling pipe should be placed in the bottom of the tank. An access port should be placed above the filling pipe.</li><li>• If the collection tank is used as a storage/disinfection facility, it needs compartments to allow for 12 month storage (or two separate tanks).</li><li>• The tank needs to be equipped with an outlet to prevent overflow. This outlet should ideally be equipped with an alarm. It should not be connected to the graywater treatment if any other solution is possible.</li></ul>

### Storing and disinfection

As mentioned above, it is recommended that blackwater be stored for at least 12 months before use. This applies to both multi-user and individual use. There are digesting systems (wet composting and bio-gas reactors) available, but they are only economical if a large number of households are connected.

	Design
<b>The system</b>	<ul style="list-style-type: none"><li>• No metals in the system to avoid metal contamination of the blackwater. No ventilation or open surfaces to avoid loss of nutrients (nitrogen).</li></ul>
<b>Piping</b>	<ul style="list-style-type: none"><li>• Allow large diameters &gt;120 mm for all pipe connections.</li></ul>
<b>Storage volume</b>	<ul style="list-style-type: none"><li>• The volume is calculated based on the toilet, the number of users, filling procedures, frequency of emptying for use in agriculture, and a storage time of at least 12 months.</li><li>• The blackwater can be stored in simple, concrete structures provided with a seal. Blackwater smells, so the construction needs to be enclosed or located in a place where people are not affected.</li><li>• Other storage systems (such as PVC-balloons) that are used for agricultural purposes (liquid manure) may also serve for blackwater storage.</li></ul>

### Use in agriculture

The potential for use of blackwater in agriculture depends on what crops the farmer grows and his/her equipment. Using ordinary agricultural equipment for spreading manure is usually the most economical solution.

<b>Crops</b>	<ul style="list-style-type: none"><li>• Any crop that will be processed after harvest.</li></ul>
<b>Nutrients</b>	<ul style="list-style-type: none"><li>• Blackwater is a well-balanced (NPK) source of nutrients and contains easily accessible plant nutrients. Swedish researchers reports that the NPK-ratio in blackwater is 12-1.4-3.9</li><li>• Blackwater is a good soil conditioner (good humus content).</li><li>• The nitrogen is easily lost if the urine is not stored and spread appropriately.</li></ul>
<b>Spreading blackwater</b>	<ul style="list-style-type: none"><li>• Manure spreading equipment can be used.</li><li>• Spreading should take place on a cloudy and humid day.</li><li>• Spreading should be carried out as close to the ground as possible (avoid spraying into the air).</li><li>• Plough down the blackwater as soon as possible after spreading, to avoid human exposure and loss of nutrients.</li><li>• As an extra sanitary precaution, blackwater should not be spread on a growing crop.</li></ul>

## Blackwater systems – Extremely low-flushing toilets

The blackwater system is based on an extremely low-flushing toilet. A urine-diverting, double-flush toilet can

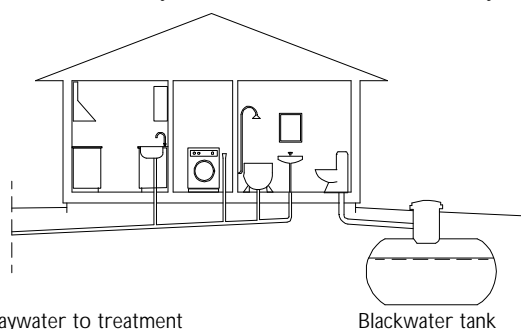

also be used. The wastes and water from the toilet are collected in a separate tank. There are two purposes in limiting the water added to the tank: i) to reduce the volume that needs to be managed (stored, disinfected, etc.) and ii) to produce a more concentrated and useful product for the farmer. Organic household wastes can also be added to the blackwater. Research has found that the decomposition process benefits from this. The graywater needs to be treated, mainly for its high content of organic matter, but also to limit the health and environmental risks involved in releasing the graywater into the recipient.

### Equipment and Dimensions

For a household (of 5 persons) the system requires the following equipment:

	Household	Volume per person and year
Blackwater tank <sup>8</sup>	10 m <sup>3</sup> collection+10 m <sup>3</sup> storage or 5 m <sup>3</sup> (6 months collection)	~1-3 m <sup>3</sup> (depending on manufacturer)
Graywater treatment	See pages14-15	

### Installation

A system with a low-flush toilet makes it more important to carefully follow the installation instructions from the manufacturers. The various manufacturers have different requirements for maximum length and minimum slope of the pipe from the toilet to the tank. A urine diverting, double-flush toilet may be used (see page 8). The limitations and requirements for an extremely low-flush toilet are much stricter. Below are some of the issues to keep in mind.

- Be sure to follow the installation instructions from the manufacturer.
- The elevation of the outlet pipe is especially crucial.

If a urine diverting toilet is used:

- Leakage of urine creates an odor problem. Leakage in the connections in the urine pipe has been one recurring problem, according to Swedish research. **Leakage can be avoided by making connections correctly.**
- Blockage in the urine trap is a recurring problem. Normally this is easy to take care of with regular maintenance. As a preventive measure, however, **The connections should be removable, in case a change of trap is needed.**

The illustrations below show mounting requirements for one model of low-flushing toilet available on the Swedish market.



Gustavsberg,  
Model Miniflush.

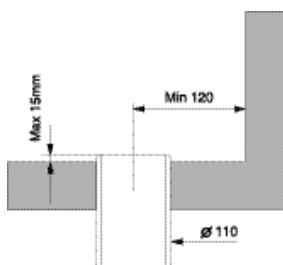

An existing outlet can be used as long as the required measurements are correct.

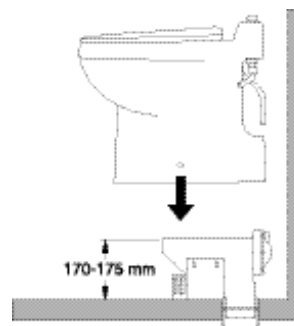

The toilet is placed and mounted on the trap..

<sup>8</sup> The collection and storage volumes are based on toilet using 0,7 l/flush

## Use and maintenance

The system needs regular attention and maintenance. There are some issues more connected to the user and his/her behavior and others that are more mechanical.

### User issues

Well-informed users are motivated to make the system work. The blackwater in itself contains only what has passed through our body: food residue, pathogens, and small amounts of heavy metals. The amount of heavy metals in blackwater is less than in commercial fertilizers. To avoid adding unwanted items and chemicals into the soil (and, subsequently, into food production), avoid putting them in the toilet.

- All detergents used in the toilet should be eco-labeled and biodegradable.
- Do not pour or throw anything in the toilet that doesn't belong there. The toilet should not be used for disposal of any waste other than toilet waste.

### Emptying the blackwater tank

Some things to consider:

- A pump is required to empty the tank. The mixture may be quite viscous, depending on how much organic household waste has been added. A pump that can handle dry matter content up to 10% is required.
- Before emptying the tank, the content should be mixed (this could be done by pumping around the mixture in the tank before taking it out) to get a homogenous mixture and avoid difficulties in emptying parts of the tank due to high viscosity.
- The tank needs to be emptied regularly. Otherwise, there is a risk of depositions on the bottom, that over the years become encrusted and thereby gradually reduces the available volume.
- Wear protective clothes when working around the blackwater for sanitary protection.

### Composting – storage of blackwater

Most of the pathogens in wastewater are collected in the blackwater. The risks of working with or using the untreated product can be expected to be relatively high. No major risk assessment has been carried out on working with and using of blackwater. The recommendations are therefore based on experience and recommendations for other wastewater products, such as sludge from wastewater treatment plants.

- The blackwater needs to be disinfected by either high temperatures or storage time exceeding 12 months.
- Storage volumes that allow **at least 12 month** of storage (without additional filling).

## Environmental and health protection

### Treatment efficiency

With this system 90-95% of all nutrients, 25% of the organic material and most pathogens are collected, rather than released into the environment, where they become pollutants.

### Human exposure and risks

As mentioned above, there has not been any risk assessment done for blackwater. There are research projects going on, and in a few years more reliable information will be available.

The greatest risk with blackwater is when it is untreated. Therefore, the system should provide for as little human exposure as possible.

More research is needed on the hazards of pharmaceutical and hormone residue in blackwater. What is known, however, is that the microbial life in soil is far better equipped to degrade naturally existing hormones and organic compounds than aquatic life. This suggests that there are lower risks associated with using blackwater in agriculture than with treating wastewater in a conventional treatment plant and releasing it to lakes or streams.

## Graywater treatment

Graywater is the mix of wastewater from kitchen, bathroom and laundry, without the toilet waste. It makes up the largest volume of wastewater but contains very limited amounts of nutrients. However, the content of organic matter and pathogens (even though limited) makes it necessary to treat graywater. This is done by a biological process in an aerated filter. Simple infiltration in a vegetated ditch may be enough, but often a more technically designed system such as vertical filtration in soil is preferred. Below two types of vertical soil filter systems that are frequently used in Sweden are described.

### Planning and design

Graywater treatment systems, including pipes, septic tank, and soil filter, must be located at a safe distance from the groundwater level and from extracting points for wells. As a rule of thumb, the distance between the infiltration layer in the soil filter and the groundwater level should be at least one meter. The filter should be located downstream from any drinking wells and never closer than 20 meters from the extracting point.

The dimensioning criteria for infiltration or a constructed soil filter are very similar. First, fats and particles have to be removed from the water to avoid clogging of the filter. Normally a septic tank is used for this. The septic tank should have at least two chambers, with the first one should be the largest. Hydraulic load should not exceed  $0,5 \text{ m}^3/\text{m}^2 \cdot \text{h}$ . A total volume of one cubic meter is normally enough for one household.

### Infiltration system

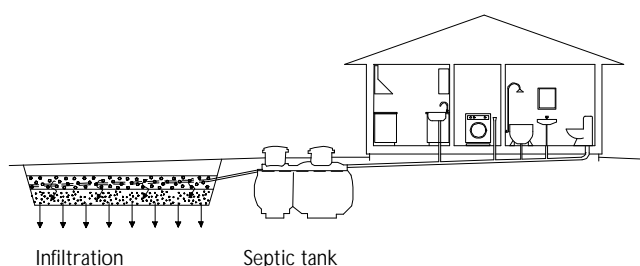

In an infiltration structure, the wastewater percolates through a diffusion layer into the natural ground material. In between the two layers, a bio-film gradually develops which treats the organic matter and pathogens. Treatment continues until the water reaches the ground water. Phosphorus and nitrogen reduction takes place in the top layers.

Infiltration is only possible if the soil layers are porous enough, but the velocity of infiltration must allow for sufficient retention time. Infiltration can be used when the natural soil is porous enough and ground water is an acceptable recipient for the purified water. If soil contains more than 10% fine material ( $< 0.1 \text{ mm}$ ) it cannot be used for infiltration due to the risk of clogging. In such a situation the hydraulic capacity of the natural soil can be strengthened by using filter sand as an infiltration medium. Ideal filter sand is made up of round 1-2 mm particles of silica (not containing fine material, clay, or calcareous material). An infiltration facility gradually loses its capacity to reduce nutrients and needs to be reconstructed every 20-25 years.

### Constructed Soil Filter

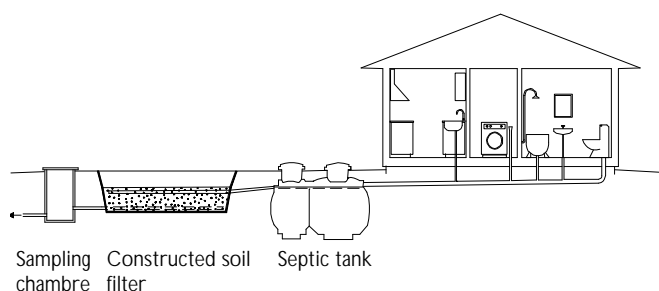

If soil conditions and groundwater protection aspects do not allow infiltration, a constructed soil filter is an option. The filter is composed of different layers of materials, and the water is treated as it passes through the filter. An aerated layer provides for bio-degradation of pathogens and organic matter, while phosphorus is reduced by adsorption to the material. Finally, the water is collected and discharged

at a selected point. The filter gradually loses its capacity to reduce nutrients and the filter material needs to be replaced every 20-25 years.

## Technical requirements

### Infiltration system

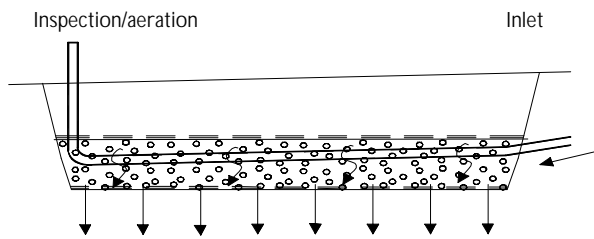

### Constructed soil filter

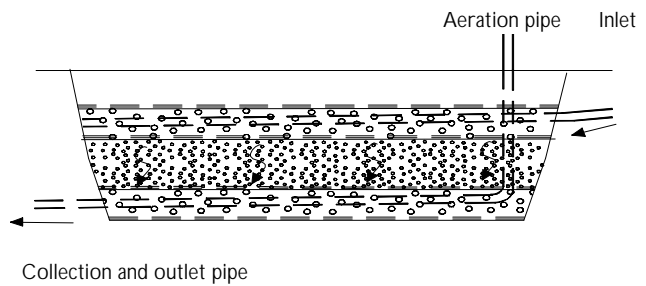

The table below summarizes some of the main issues to consider :

### Infiltration system

#### Structure

- The construction height is about 1,5 m. The structure can partly be placed above ground, (a mound) but it may then be necessary to pump the graywater through the system
- To protect from frost, the pipe must be covered with 40-60 cm soil. If the system is used daily, the risk of frost damage is very limited.
- In the case of two or more parallel trenches, the distance between distribution pipes should be at least 2 metres (measured from centre to centre). The bottoms of the two (or more) trenches have to be at same level to avoid uneven loading
- The bottom area should be horizontal and the slope of distribution pipe  $>0.5\%$
- The bottom width should be approximately 1 m (may vary between 0.8 and 2 m)

#### Materials

##### Distribution pipe

- Pipe with min.  $d = 80$  mm. with holes, 8-10 mm in three straight lines on one side
- Place pipe with lines of holes facing down

##### Spreading layer

- Well graded and washed material. 15-30 mm
- Minimum 10 cm thickness under the lowest point of the distribution pipe

##### Re-filling material

- Remains from the excavation of the ditch. Needs to be 40-60 cm on top of the spreading layer

##### Material separation

- A geo-textile to prevent the re-filling material to blend with the spreading layer.

##### Inspection pipe

- An inspection pipe at the end of the distribution pipe to secure the function and for aeration

### Constructed soil filter

#### Structure

- The construction height is about 2 m. The structure can partly be placed above ground, but the graywater may then have to be pumped through the system.
- The location of the structure is determined by: i) outlet from septic tank, ii) groundwater and/or bedrock level, iii) surface level of recipient.
- The structure has a distribution pipe and a collection pipe. To allow gravity flow, pipes should be laid at a slope of  $>0.5\%$
- The bottom width should be approximately 1 m (may vary between 0.8 and 2 m)
- A separating layer should be placed in between different materials

#### Materials

##### Distribution and collection pipes

- Pipe with min. diameter 80 mm. With holes, 8-10 mm in straight lines in the bottom. Best spreading is achieved with three rows, (at 5,6 and 7 o'clock).
- Lay the pipe with holes facing down

##### Material separation

- A geo-textile to prevent the re-filling material from blending with the spreading layer.
- Material separation between filter sand and collection layer should be well graded material, 4-10 mm.

##### Spreading layer

- Well graded and washed material, 15-30 mm. Minimum 10 cm thickness under the lowest point of the pipe

##### Filter material

- Well graded and washed sand  $<8$ mm.

##### Collection layer

- Well graded, washed material, 8-16 mm or 12-24 mm. Approximately 15 cm thick.

##### Re-filling material

- Soil from the excavation of the trench, 40-60 cm on top of the spreading layer

##### Aeration pipe

- The collection pipe should have an aeration pipe at the inlet.

##### Inspection and sampling chamber

- There should be an inspection chamber ( $d = 300$  mm) at the outlet.

##### Collection and outlet pipe

- The collection and outlet pipe should be placed in slope of  $>0.3\%$

## Literature

Etnier, C. et al. 1997. *Ecotechnology for wastewater treatment: Functioning facilities in the Baltic Sea region*. Coalition Clean Baltic: Gdansk.

Ridderstolpe, P. 1999. *Wastewater treatment in a small village: Options for upgrading*. Coalition Clean Baltic, SwedEnviro report 1999:1.

Johansson, M. Lennartsson, M. *Sustainable wastewater treatment for single-family households*. Coalition Clean Baltic, 1999

Swedish EPA Report No 87:6, *Små avloppsanläggningar, hushållsspillvatten från högst 5 hushåll*, (Small wastewater treatment systems, household wastewater from up to 5 households)

Johansson, M. et al., *Småskalig Avloppsrening* (Small-scale wastewater treatment), Formas (Swedish research council for environment, agricultural science and social planning), 2001

Höglund, C. *Evaluation of microbial health risks associated with the reuse of Source-separated human urine*, Doctoral thesis, Royal Institute of technology (KTH), Swedish Institute for Infectious Disease Control (SMI) 2001

Vinnerås B., 2001. *Feecal separation and urine diversion for nutrient management of household biodegradable waste and wastewater*, Swedish University of agricultural science, SLU Department of agricultural engineering, Report No. 244

Johansson, M. et al., *Urine separation – closing the nutrient cycle*. Formas (Swedish research council for environment, agricultural science and social planning), 2001

**This brochure is sponsored by the European Commission,  
Environment DG.**

 Coalition Clean Baltic



In Helsinki, February 1990, non-governmental environmental organisations from nine countries of the Baltic Sea region united and established Coalition Clean Baltic (CCB) in order to co-operate on activities for protection of the Baltic Sea environment. CCB is a politically independent, non-profit association. Currently CCB unites 24 member organisations from the Baltic countries. CCB gathers, produces and distributes information on environmental solutions for the Baltic Sea region. CCB co-operation projects provide assistance to the member organisations in their efforts to restore the Baltic Sea. Sustainable management of wastewater is a priority area for CCB.

**Coalition Clean Baltic**  
**Östra Ågatan 53**  
**S-753 22 Uppsala**  
**SWEDEN**  
**Telephone: +46 18 71 11 70**  
**Telefax: +46 18 71 11 75**  
**www.ccb.se**

SwedEnviro Consulting Group is an association formed by Swedish environmental consulting companies working with water and soil management, waste and wastewater treatment for sustainable use of natural resources. The companies in SwedEnviro are: EcoManagement SE, Vattenresurs AB, VERNA Ekologi AB and WRS Uppsala AB. SwedEnviro's work focuses on sustainable development with an optimal use of resources.

**SwedEnviro Consulting Group**  
**Malmgårdsvägen 14**  
**S-116 38 Stockholm**  
**SWEDEN**  
**Telephone: +46 8 641 75 00**  
**Telefax: +46 8 702 12 80**  
**www.swedenviro.com**

© Coalition Clean Baltic

December 2001